

Duct Hygrostats

for relative humidity

QFM81...



QFM81.21



QFM81.2

**On/off hygrostat with microswitch,
with temperature-compensated humidity sensor for temperature-independent
humidity measurements,
with stabilized sensing strip (good linearity, very stable even at high humidity,
insensitive to dust and contaminated air),
for the control of humidification equipment,
for the control of dehumidification equipment,
for mounting in ventilating ducts or rooms**

Use

The duct hygrostats are designed for controlling and monitoring the relative humidity in ventilating and air conditioning plants.

They control the humidity content of the air within an adjustable range of 15 to 95 % r.h. In air conditioning plants with humidification, the duct hygrostat can also be used as a maximum limiter in the supply air duct.

In laboratories or production facilities, the duct hygrostat can also be used as a minimum limiter in the supply air duct.

Type summary

Type reference	Setpoint range (W_h)	Switching differential (X_d)	Degree of protection	Setpoint adjustment
QFM81.2	15...95 % r.h.	approx. 4 % r.h.	IP 30	externally
QFM81.21	15...95 % r.h.	approx. 4 % r.h.	IP 55	internally

Ordering and delivery

When ordering, please give name and type reference; for example:
duct hygrostat **QFM81.2**

The delivery comprises the hygrostat, a mounting flange (for duct or wall mounting) and a sealing ring (for duct mounting).

Mode of operation

The hygrostat acquires the relative humidity of the air with its humidity sensor, which is a stabilized plastic texture strip. The strip actuates a microswitch with a fixed switching differential X_d and a potential-free contact output (S.P.D.T.), depending on the relative humidity of the air. If the actual humidity deviates from the adjusted setpoint, the hygrostat switches the associated humidification or dehumidification equipment on or off as shown in the following function diagram.

Function diagram

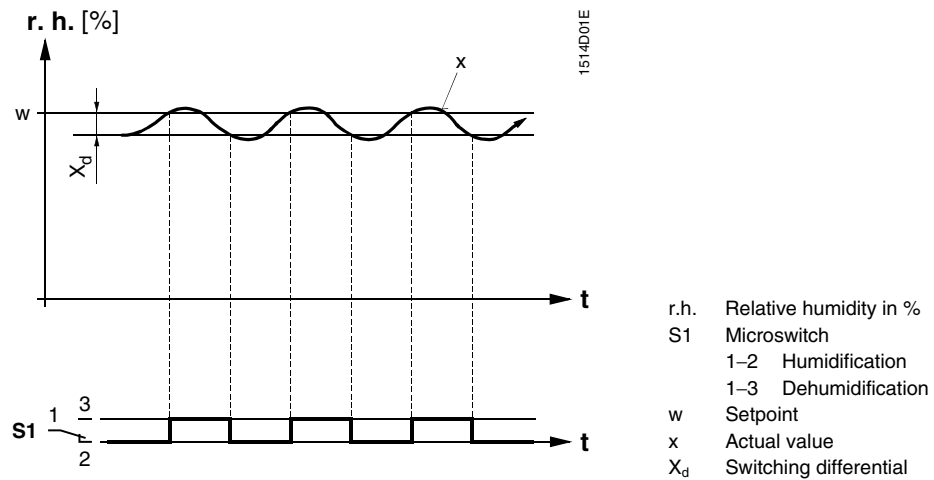

If the relative humidity exceeds the adjusted setpoint, the potential-free contact of the microswitch will change over from 1-2 to 1-3. If the relative humidity falls by the amount of the fixed switching differential X_d , the contact will return to the position 1-2.

Mechanical design

QFM81.2

The hygrostat consists of base with immersion sensor stem and cover. The cover is secured to the base with a screw.

The stem accommodates the temperature-compensated humidity sensing element (stabilized plastic texture strip). The strip is mechanically linked to the microswitch via a transfer lever. Transfer lever, microswitch, setpoint setting element and connection terminals for connecting the humidification or dehumidification equipment are mounted on a printed circuit board inside the base. The connection terminals are protected by a hinged cover to avoid direct access when the cover is removed.

The cover has a hole for the setpoint knob. The hygrostat is designed for mounting in air ducts, but can also be mounted on a wall. For both mounting methods, a mounting flange is required, which is supplied with the unit.

QFM81.21

Same design as the QFM81.2, but with an additional transparent cover on the hole for the setpoint knob, cable gland Pg 11, and seal under the unit cover.

Setting elements

Setpoint knob

On both units, the setpoint is adjusted with the setpoint knob. The setting scale is on the unit cover.

With the QFM81.21, the setpoint can be adjusted only when the cover is removed.

Mounting notes

Air duct mounting

If the duct hygrostat is used for control, it is to be mounted in the extract air duct after the room to be controlled.

If the duct hygrostat is used for monitoring the maximum or minimum humidity level, it is to be mounted in the supply air duct.

Mounting positions

The immersion sensor stem must be mounted either horizontally or vertically with the stem pointing downward. It may never be mounted with the stem pointing upward. To ensure accurate humidity measurements, it must be made certain that the air to be measured is sufficiently mixed at the point of measurement.

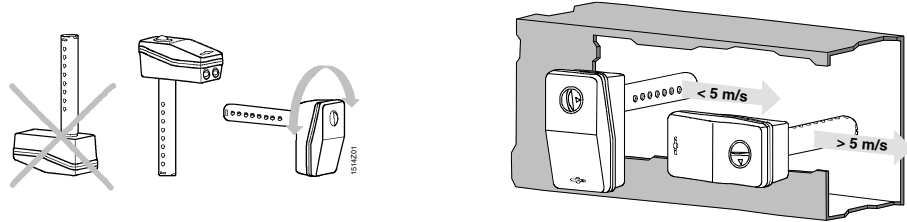

The mounting orientation is dependent on the air velocity in the ductwork: at < 5 m/s, the holes in the stem must face the air flow; at > 5 m/s, they must be perpendicular to the direction of air flow (see illustration above).

Minimum immersion length

When mounting the hygostat in air ducts, the minimum immersion length of the stem (130 mm) must be observed. The mounting flange supplied with the unit allows the immersion length to be adjusted between 130 and 156 mm.

Wall mounting

The hygostat should be mounted on an inner wall approximately 1.5 m above the floor and at least 0.5 m from the next wall. At the location where the unit is mounted, there should be a natural circulation of room air (no draughts, no corners of the room, not behind curtains, not too close to doors and windows, and not on an outer wall). Sources of heat and refrigeration (radiators, computers, TV sets, concealed heating pipes, hot or cold water pipes) must be in an adequate distance. The hygostat should not be exposed to direct solar radiation. For wall mounting, the mounting flange supplied with the hygostat must be used.

Mounting instructions

The unit is supplied with mounting instructions.

Technical data

Setpoint range	15...95 % r.h.
Control mode	on/off
Switching differential	approx. 4 % r.h. (fixed)
Type of switch	potential-free microswitch (S.P.D.T.)
Contact rating	
Maximum	5 (3) A, AC 250 V
Minimum	100 mA, AC 24 V
Temperature influence	compensated
Long-term stability	approx. -1.5 % r.h./a
Balancing	at 55 % r.h., 23 °C
Time constant ($v = 0.2$ m / s)	approx. 3 min
Perm. air velocity	10 m/s
Perm. ambient temperature	
Operation	0...70 °C
Storage / transport	-30 ...+70 °C
Degree of protection	
QFM81.2	IP 30 to EN 60 529
QFM81.21	IP 55 to EN 60 529
Safety class	II to EN 60 730
CE conformity to low voltage directive	73/23/EEC
Connection terminals for	0.5 mm dia. min. 2 x 1.5 mm ² max.
Materials	
Sensing element	Polymer
Casing with stem	PPS, Fortron 1140L6, glass fibrereinforced
Cover	PC Lexan 940
Transparent cover (only with QFM81.21)	PC Makrolon 2014R, transparent
Weight	approx. 0.34 kg
Maintenance	maintenance-free, can be recalibrated

Internal diagram

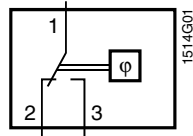

- 1-2 Humidification
- 1-3 Dehumidification

Dimensions

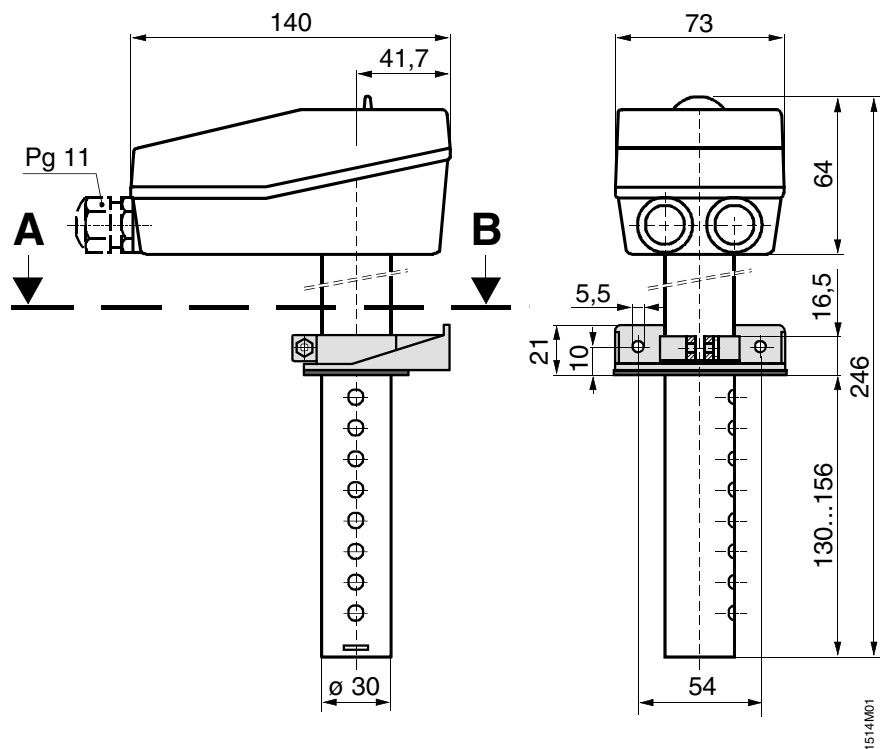

A - B

